

- ✓ **Smooth Markings**
- ✓ **Transverse Bead Markings**
- ✓ **Diagonal Bead Markings**
- ✓ **Structure Markings (with spiked roller)**
- ✓ **SPOTFLEX® Markings**

Newly developed 2-component cold plastics bellow pump system M 98:2 For machines H33, H26, H18

The core piece is a specially developed feed pump for highly-viscous plastics with features that are especially important for the road marking area.

Special Features:

1. Exact static pump working method: The feed rate per rotation of the control valve is always the same, no matter the speed, counter-pressure or viscosity (until the hydraulic safety valve reacts).
2. No wear (even in case of highly abrasive media) which could reduce feed accuracy, since the displacers are not touching the walls of the pump chambers. Filling materials with a grain size of up to 2,5 mm pose no problem.
3. The pump is completely made of steel. There are no problems with solvents in the feed medium. The pump may always remain filled with paint.





4. The pump has a hydraulic drive; the feed rate is set electronically.
Two operating modes:

- AMAKOS®: Travel-dependent pump control for adjusting marker the paint feed according to speed.
In this operating mode, you may adjust marking speed within a wide range. The desired amount set per metre of line length will always remain the same.
- Non- AMAKOS®: Constant feed rate independent of marking speed.
In this operating mode, changing the speed always also changes the amount per metre of line length.

5. Pump arrangement (for parent component and curing agent) on the machine's frame, usually at the paint container, mixers with application aggregates are supplied through hoses.
6. The mixer with application aggregates can be stagelessly pushed under the machine frame from outer lateral position of the machine on one side over the centre position to the other outer lateral position. Therefore, lines can also be painted from the machine centre. However, there may be limitations regarding the type and number of bead spraying aggregates.

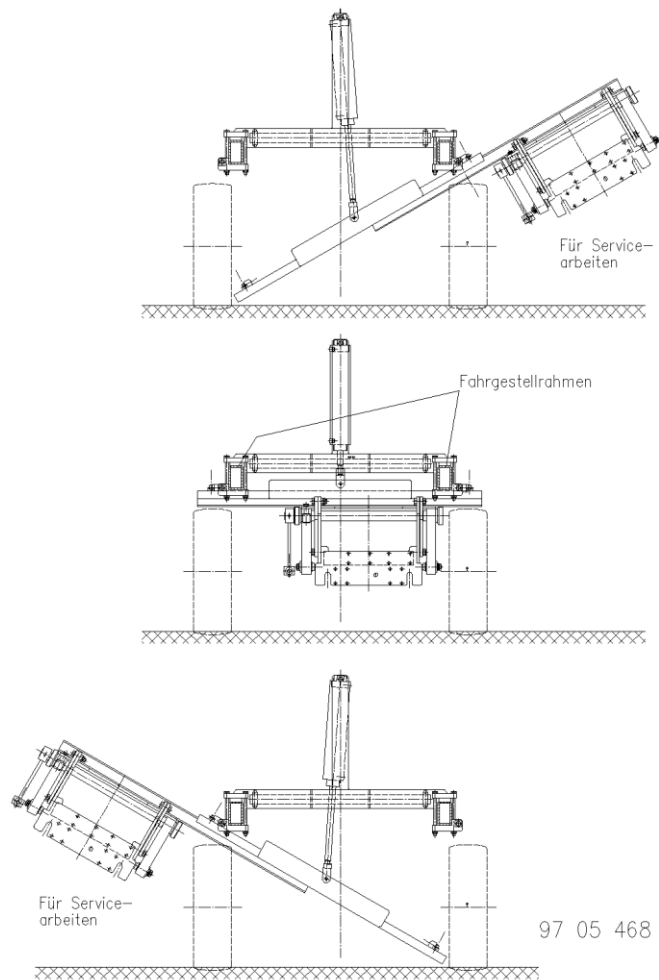

- 7. Mixers with application aggregates are vertically guided in a parallelogram and can pneumatically be lifted by approx. 15 cm.
- 8. Additional lifting and tilting into a 30° position is possible in the outer positions (pneumatically) for good accessibility during service work.

Maximum power of parent component pumps 35 l/min. This allows following maximum marking speeds at an application rate of 2.5 kg / m², if no other limits require lower speeds.

Line width (cm)	Material consumption kg/m	Max. Speed m/min.	Max. Speed km/h
12 cm	0,3	216	13
15 cm	0,37	173	10,4
24 cm	0,6	108	6,5
30 cm	0,75	86,5	5,2